



# OMC-116 Installation manual



---

## Revision History

V1.01	August 2012	First release
V1.02	January 2015	<ul style="list-style-type: none"><li>- Revised connection board.</li><li>- OMC-116-M</li><li>- Heated Bracket option</li></ul>
V1.03	June 2020	<ul style="list-style-type: none"><li>- Update range wind speed</li></ul>

---

## **Introduction**

This manual describes the installation of the OMC-116 ultrasonic wind sensor. Installation must be carried out by a qualified engineer. This manual assumes the engineer has basic knowledge of electronics. We recommend reading this manual before installation of the sensor.

---

## Pre installation notes & requirements

The OMC-116 can't be directly powered by an Obsermet display (like OMC-138/139) or data collection unit (like the OMC-183/184). A separate power supply is required:

12 -15Vdc 1A            when no heating is required  
24Vdc    10A            when sensor heating is required



**The heating is temperature and voltage controlled, do not use a 24V power supply <10 A.**

## Recommended cabling:

Without heating (12-15Vdc):            2x2x0.75 mm<sup>2</sup> shielded

With heating (24Vdc, 10A):            2x2.5mm<sup>2</sup> ( power, max 30m)\* + 2x0.75mm<sup>2</sup> shielded



**\*The heating will not be operated if the voltage is below 20V. Especially when long cables are used check that the losses over the cable are acceptable and the voltage at the sensor is well above 20V. Alternatively the power supply unit must be placed closer to the sensor and/or thicker cable or a power supply with a higher voltage must be used (voltage at the sensor may not exceed 28V).**



**For Marine applications and locations with possible heavy vibrations only the OMC-116-M should be used! This model is specific designed to withstand heavy vibrations and is tested to DNV 2.4 environmental vibration class C specifications.**

## Terminals

### Sensor connections pre 2015

1. Ground (power)
2. Power (+12 .. 28 VDC)
3. NMEA 0183 B (RS422/485)
4. NMEA 0183 A (RS422/485)
5. Analogue ground
6. Analogue Wind Speed (optional)
7. Analogue ground
8. Analogue Wind direction (optional)

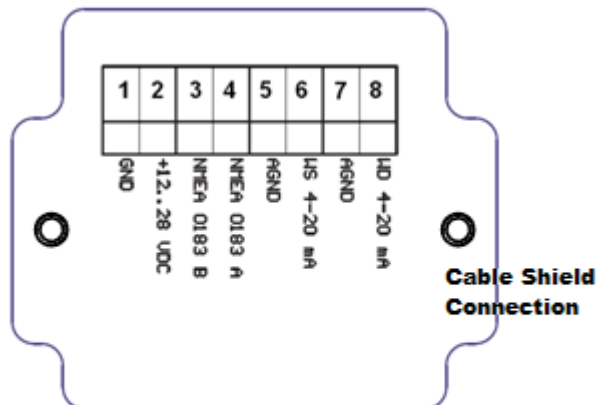

### Sensor connection from 2015

1. Ground (power)
2. Power (+12 .. 28 VDC)
3. NMEA 0183 B (RS422/485)
4. NMEA 0183 A (RS422/485)
5. **Analogue ground Wind Speed & Direction**
6. Analogue Wind Speed (optional)
7. **Control**
8. Analogue Wind direction (optional)

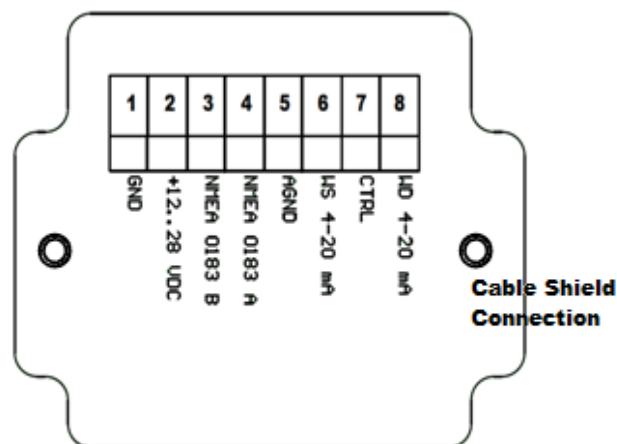

Output is either NMEA or Analogue.

## Sensor installation

The OMC-116 must be mounted **on top** of a mast (Ø 45 .. 60mm) with the included U bolts.

Make sure the sensor is free of obstacles.  
Recommended sensor height is 10m. Wind speed should be measured at 10m height however an obstacle free environment is more important.



**Bracket & U-bolt must make contact with metal of the mast to lead any static discharge to ground.** If this is not possible due to coating etc. a proper earth lead must be connected to 1 of the U-bolts.

**The mast must be correctly earthed to regulations.**

## Cable connection



**The shield of the cable(s) may not be laid to ground on the receiving (display / signal conditioning) side of the cable but must be connected on sensor side.**

The junction box does have an extra (plugged) M20 hole in case separate cables are used for signal and power.

## Alignment

The sensor must be lined up to North (fixed applications) or for ship applications to the bow of the vessel.

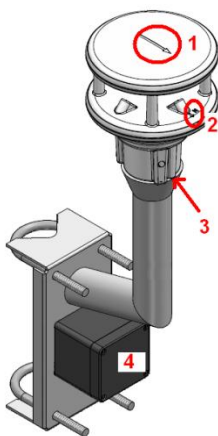

The OMC-116 has several markings indicating the North / Bow direction of the sensor:

1. Arrow on top
2. Small arrow on sensor deck
3. Drilling hole visible from below
4. Front junction box

---

**NMEA output**

The OMC-116 sensor outputs a MWV message once a second at 4800 baud:

**\$IIMWV,xxx.x,R,xxx.x,M,A\*xx(CR)(LF)**

\$IIMWV,	ID : II, MWV message type
xxx.x,	Wind direction
R,	Relative
xxx.x,	Wind speed
M,	m/s
A,	A=valid value, V= invalid value
*	Check sum identifier
xx	Check sum (high byte first)
CR	Carriage Return
LF	Line Feed

---

## Specifications

Power supply:	24 .. 28 Vdc (240W) 12 .. 15 Vdc if no heating is used (15W)
Power consumption:	+/- 1.8W/h (without heating)
Weight (incl. U bolts):	4.3 kg
Fastening:	U-bolts on top of mast Ø 45 .. 60 mm
Protection class:	III (SELV)
Protection type:	IP66
Storage conditions	
Permissible storage temperature:	-55°C ... +80°C
Permissible relative humidity:	0 ... 95% RH Non-condensing
Operating conditions	
Permissible operating temperature:	-40°C ... +60°C (with heating)
Permissible operating temperature:	-20°C ... +60°C (without heating)
Permissible relative humidity:	0 ... 100% RH
Output:	RS422/485 NMEA (MWV once a second) Baud rate 4800 (others on request) NMEA ID: II (others on request)  Analogue (4-20mA, voltage) Optional
Housing:	Powder coated Seawater-resistant aluminum AlMg3Si (Bracket RVS)
Measurement process:	Ultrasound
Measuring range wind speed:	0 – 90m/s
Resolution wind speed:	0.1m/s
Accuracy wind speed:	±0,2 m/s or ±2% RMS (the higher value)
Measuring range wind direction:	0 – 359.9°
Resolution wind direction:	0.1°
Accuracy wind direction:	< 2° (> 1m/s) RMSE
Response threshold:	0.1 m/s
Sampling rate:	1 second



**Dimensions**

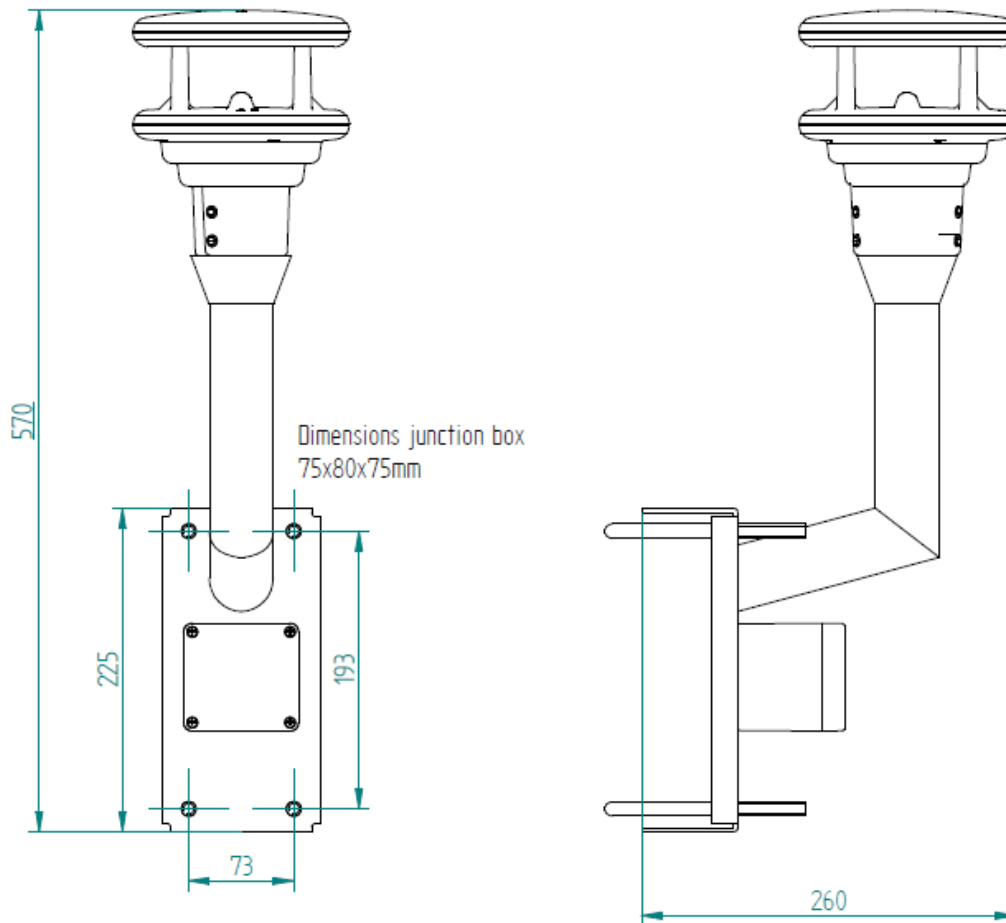
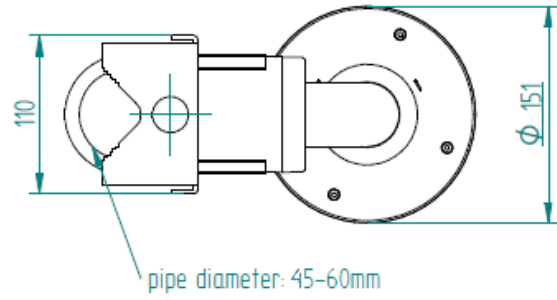

**OMC-116-M**

pipe diameter: 45-60mm

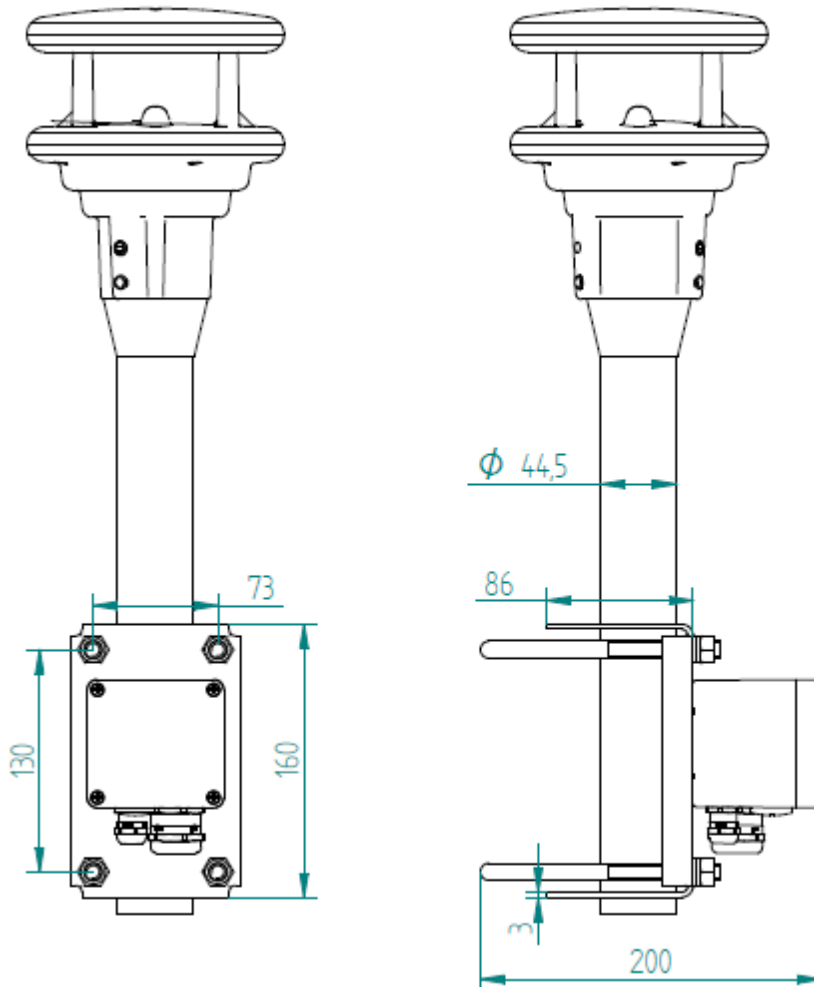
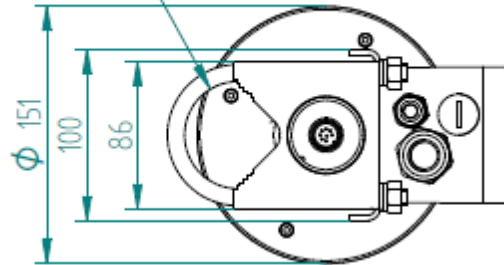

---

## Disposal

### Within the EC



The device must be disposed of in accordance with European Directives 2002/96/EC and 2003/108/EC (waste electrical and electronic equipment). Waste equipment must not be disposed of as household waste! For environmentally sound recycling and the disposal of your waste equipment please contact a certified electronic waste disposal company.

### Outside the EC

Please comply with the applicable regulations for the proper disposal of waste electrical and electronic equipment in your respective country.

## Repair / Corrective Maintenance

Please arrange for any faulty equipment to be checked and, if necessary, repaired by the manufacturer exclusively. Do not open the equipment and do not under any circumstances attempt to carry out your own repairs.

Contact your local dealer or Observator instruments: