

EVOLO 633 TWISTLOCK GRADE A-H

INTRODUCTION

The innovative EvoLo 633 TwistLock for modular and skid based units solve the vibration issues causing potential damage and noise in the units, while the flexibility and easy handling of the TwistLock is maintained.

Personnel on offshore platforms are often facing vibration challenges caused by modular and skid based units. These vibrations are transmitted throughout the steel structure and may result in unforeseen damage or failure. Additionally, these vibrations affect the living and working environments of offshore workers. Eventually, this will negatively affect production, as poor working conditions often lead to inefficiency, a decrease of morale on the platform, and noncompliance with working conditions and safety regulation.

Already successfully applied her innovative EvoLo vibration mounts in various market segments. In the offshore industry, many permanent offshore units are isolated against vibration with the EvoLo 633. However, the standard EvoLo 633 vibration mount can not be used in this case, as modular and skid based units must be secured safely whilst their deployment remains flexible. The EvoLo 633 TwistLock is the result of the combination of our vibration isolation expertise, high-quality products, and innovative capabilities. It has all the benefits of easy and quick installation of the TwistLock widely used in the offshore market, combined with the perfect vibration isolation qualities of the EvoLo 633 vibration mount. It is the ideal vibration isolator for modular and skid based units, as it protects the offshore unit from dangerous and annoying vibrations coming through and from the platform.

EvoLo 633 TwistLock improves safety by preventing the unit and structure from hazardous and inconvenient vibrations. Additionally, it substantially increases working and living conditions on the offshore platform similar to our solutions for permanent offshore units. The business benefits are legion: increased efficiency, improved morale, and compliance with offshore working conditions and safety regulation.



MATERIAL

Rubber part: Highest quality natural rubber
Metal: Steel (St. 37 electrolytic galvanized)

IDENTIFICATION

The type is marked in TAG/ Identification.

ADVANTAGES

- Type approvals available on request
- Optimum vibration isolation
- Easy and quick installation
- Build in end-limiter to protect against overload
- Capable of handling both vertical and horizontal forces
- Natural rubber gives maximum vibration isolation
- One type fits all weights between 1400 and 11800 kg
- Stock item

TECHNICAL DRAWING

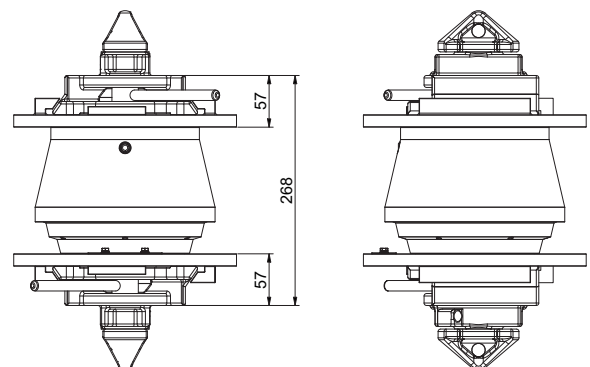
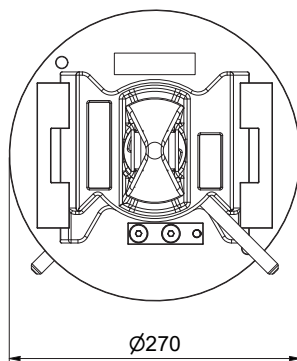

EVOLVO 633 TWISTLOCK GRADE A-H

TECHNICAL DATA

ARTICLE NO.	GRADE	MAXIMUM LOAD
1030633AT	A	118 kN
1030633BT	B	104 kN
1030633CT	C	85 kN
1030633DT	D	72 kN
1030633ET	E	38 kN
1030633FT	F	34 kN
1030633GT	G	30 kN
1030633HT	H	27 kN

STATIC VERTICAL CHARACTERISTICS

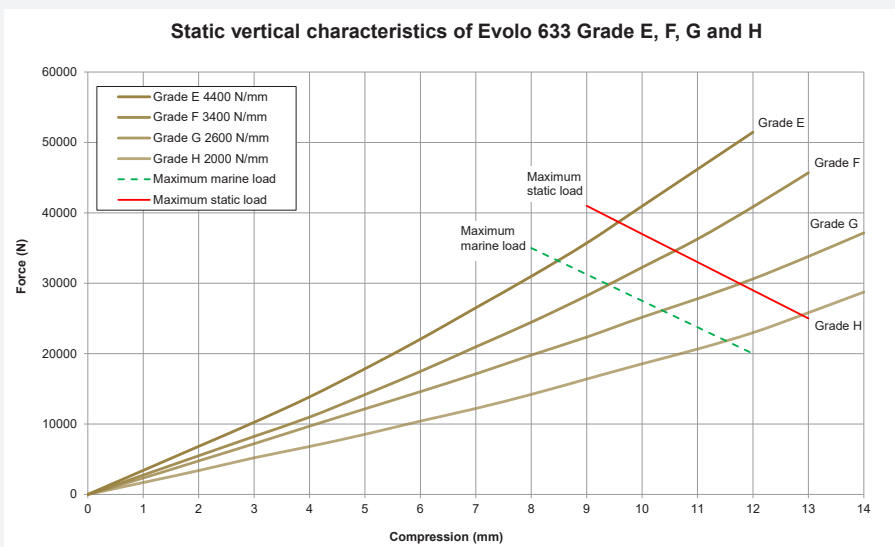
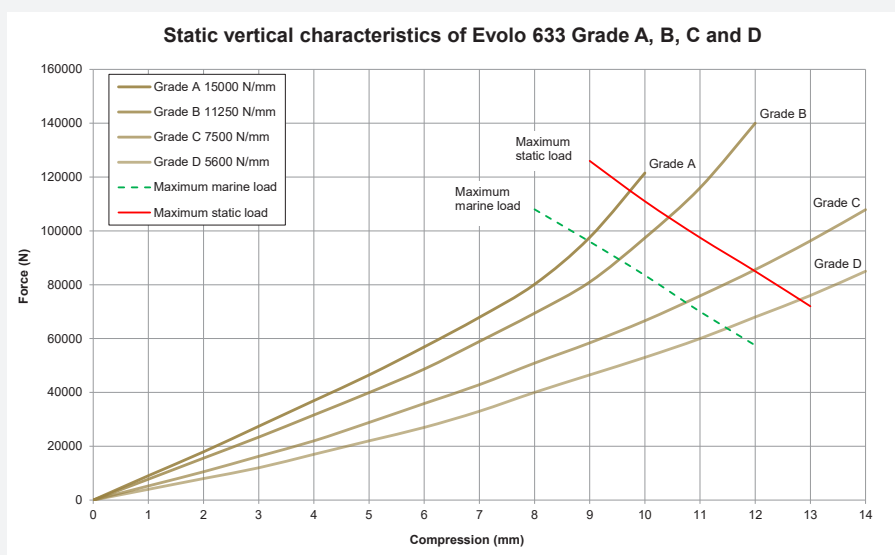

EVOLO 633 TWISTLOCK GRADE A-H

HORIZONTAL CHARACTERISTICS WHEN PRE-COMPRESSED 4 MM

