

# EVOLO 633 HEIGHT ADJUSTABLE GRADE A1-H

## APPLICATION

Optimum vibration isolation for a wide range of applications. For larger, heavy-weighted equipment under extreme conditions that needs optimal vibration isolation at both high and low frequencies, such as large generator sets, pump units, large diesel engines, compressor/cooling units, gearboxes, windmills, deck house mountings, control cabins.

## MATERIAL

Rubber part: Highest quality natural rubber  
Metal: Aluminum/Steel

## IDENTIFICATION

The type is marked in the mounting plate.

## ADVANTAGES

- No need for additional shims due to compensation of any height differences in set-up
- Type approvals available on request
- Optimum vibration isolation
- Easy and quick installation
- Build in end-limiter to protect against overload
- Capable of handling both vertical and horizontal forces
- Natural rubber gives maximum vibration isolation
- For loads between 2750 and 12.000 kg
- Stock item



## TECHNICAL DRAWING

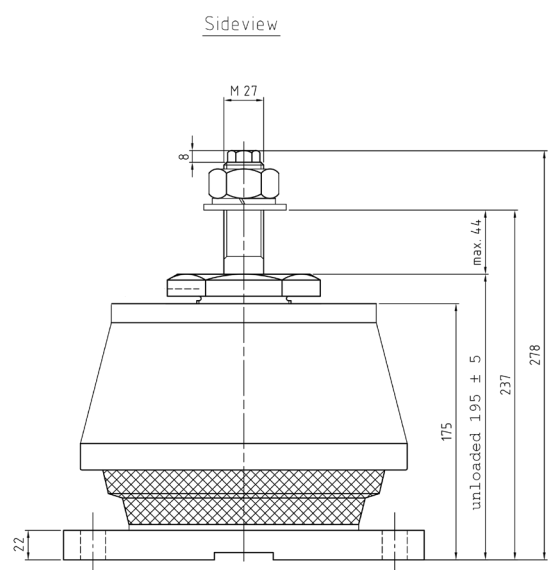
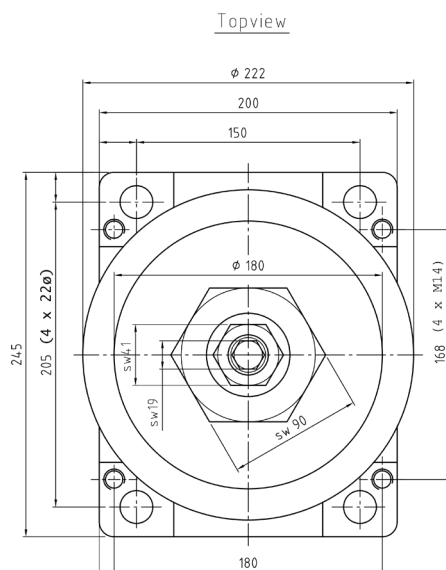

# EVOLo 633 HEIGHT ADJUSTABLE GRADE A1-H

## TECHNICAL DATA

ARTICLE NO.	GRADE	MAXIMUM LOAD
10306331H	A1	118 kN
1030633AH	A	118 kN
1030633BH	B	104 kN
1030633CH	C	85 kN
1030633DH	D	72 kN
1030633EH	E	38 kN
1030633FH	F	34 kN
1030633GH	G	30 kN
1030633HH	H	27 kN

## STATIC VERTICAL CHARACTERISTICS

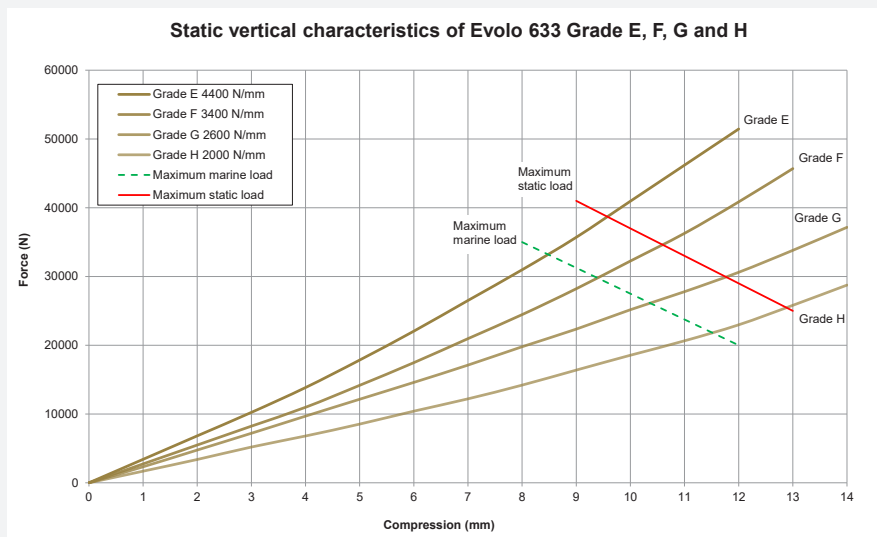
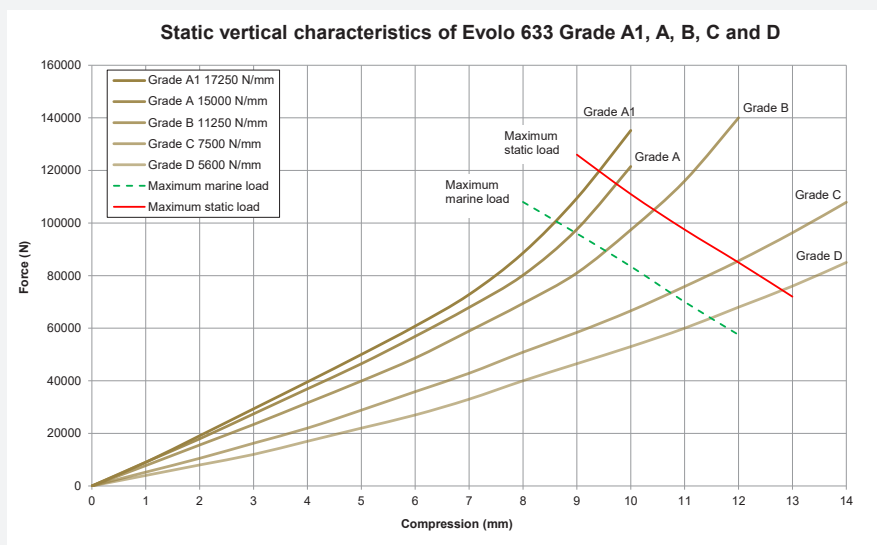

# EVOLO 633 HEIGHT ADJUSTABLE GRADE A1-H

## HORIZONTAL CHARACTERISTICS WHEN PRE-COMPRESSED 4 MM

