

EVOLO 622 HEIGHT ADJUSTABLE GRADE A-H

APPLICATION

Optimum vibration isolation for a wide range of applications. For larger, medium-weighted equipment under extreme conditions that needs optimal vibration isolation at both high and low frequencies, such as generator sets, pumps, diesel engines, compressor units, ventilators, measuring equipment, small deck houses, cabins, cooling units, etc.

MATERIAL

Rubber part: Highest quality natural rubber
Metal: Aluminum/Steel

IDENTIFICATION

The type is marked in the mounting plate.

ADVANTAGES

- Approved by Lloyd's Register
- Optimum vibration isolation
- Easy and quick installation
- Build in end-limiter to protect against overload
- Capable of handling both vertical and horizontal forces
- Natural rubber gives maximum vibration isolation
- One type fits all weights between 50 and 2200 kg
- Stock item



TECHNICAL DRAWING

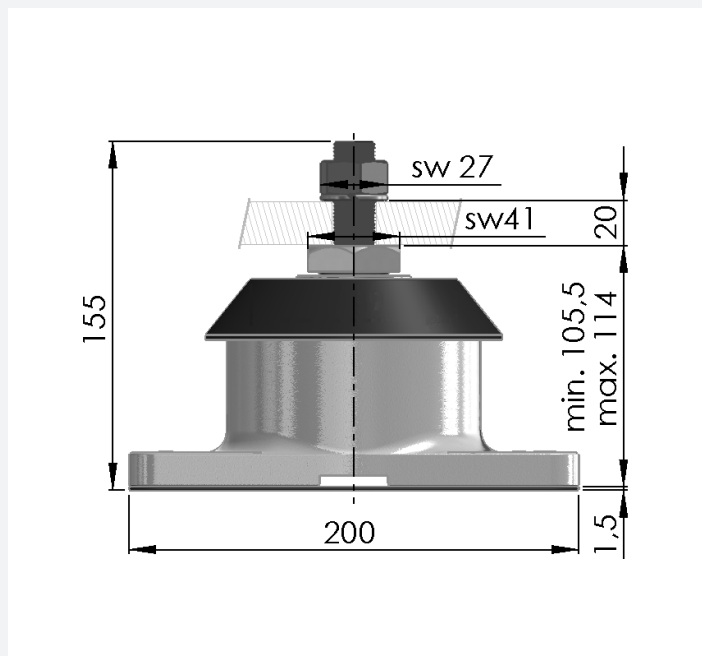
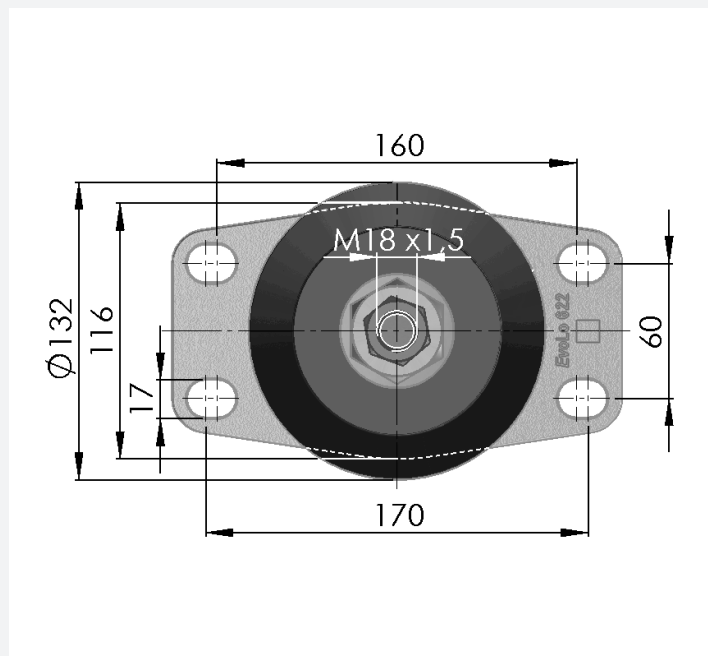

EVOLo 622 HEIGHT ADJUSTABLE GRADE A-H

TECHNICAL DATA

ARTICLE NO. WITH HEIGHT ADJUSTMENT	GRADE	MAXIMUM LOAD
1030622A1	A	22000 N
1030622B1	B	16500 N
1030622C1	C	12000 N
1030622D1	D	8500 N
1030622E1	E	4000 N
1030622F1	F	2750 N
1030622G1	G	1900 N
1030622H1	H	1300 N

STATIC VERTICAL CHARACTERISTICS

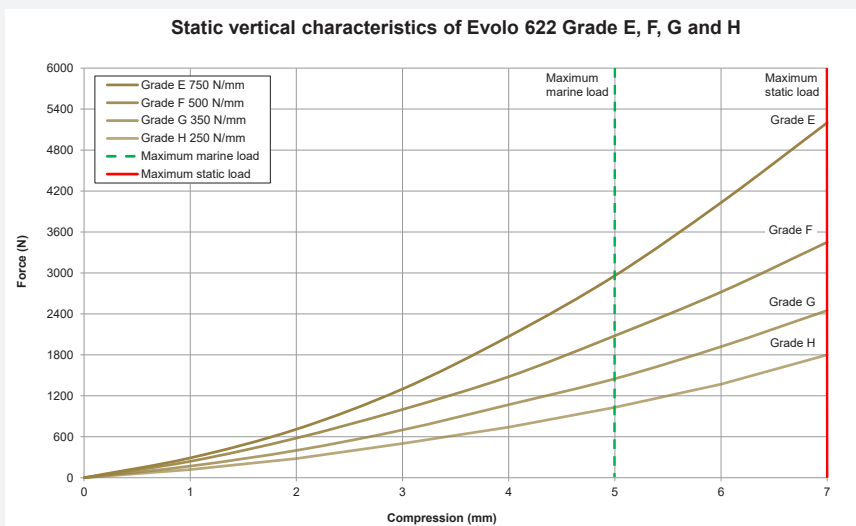
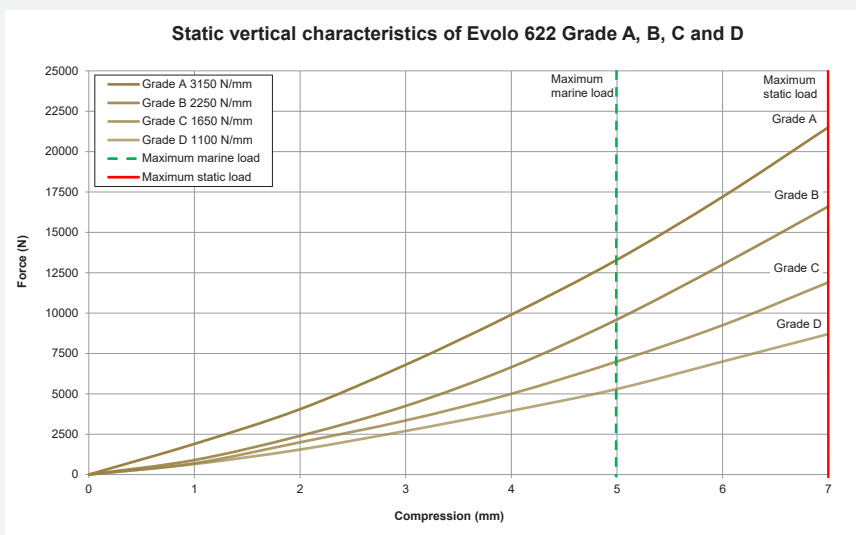

EVOLO 622 HEIGHT ADJUSTABLE GRADE A-H

HORIZONTAL CHARACTERISTICS WHEN PRE-COMPRESSED 4 MM

